

February 2015
Newsletter No. 153

AIRTOURER ASSOCIATION



Dedicated to the preservation and continued airworthiness of VICTA and AESL Airtourer Series Aircraft



NEWSLETTER

<http://www.Airtourer.asn.au>

Editor, John O'Halloran	Mobile:	0411 968901
P.O. Box 778,	FAX:	(07) 54425180
Tewantin QLD 4565	Phone:	(07) 54476604
	Email	Editor@Airtourer.asn.au

Articles for inclusion in the Newsletter should be submitted direct to John O'Halloran at the contacts listed above.

The next Newsletter will be published in May 2015. Contributions and or advertisements are to be with JOH by 15 April 2015.

Advertisements are free for current members.

Editorial

I trust that most of you have survived the festive season safely. As I work on this issue in Hong Kong the Christmas and New Year decorations have given way to the traditional Chinese New Year lights.

Your Committee has been hard at work preparing for the Convention and AGMs at Bathurst. They have put together a full program that will keep us on the go the entire weekend. All the details are in this Newsletter as well as on the website. Keep checking the website for the latest updates. You can also register on-line.

The AGMs are planned for the Sunday morning as usual. Please remember that the AGMs are primarily for transacting the essential legal business such as the financial reports as well as other important business. Topics that are not so important as to require consideration by the membership at the AGM should be addressed to the Committee/ Board throughout the year or to the general membership via the Newsletter.

Our President has noted the change in leadership at CASA. Mark Skidmore, the new Director shared an office with me in the past. I have the highest regard for him as a pilot, especially a test pilot, and as an administrator. It's a thankless job with many conflicting inputs from political agendas to international obligations. Mark owns a Globe Swift and is aware of the challenges of GA. We wish him well.

Safe Airtouring,

John O'Halloran

Cover Photo: Airtourer UQX after it was restored by the Frank Fankhauser, on the right in the picture.

Disclaimer

The views expressed are those of the contributors and not necessarily those of the Publishers, the Airtourer Association or the Airtourer Co-operative Ltd.

From The President No. 8



Last November, which seems so long ago, Gerry Pels and I flew up to Bathurst in BNV to meet with the Aero Club and do the ground work for this year's AGM.

We departed KTN in smooth flying conditions and arrived at BTH to hot gusting winds. I now know why Gerry has a Piper Arrow, he is a big fellow. It was like flying with an octopus, wherever you looked there was an arm or a leg taking up the limited space in the Airtourer. Pull on the brake and a scream fills the headset as the RH handle removes a knee cap; sorry Gerry!. Once on the ground things became very hectic but by the next day a viable programme had emerged so we could fly home. Again the departure from BTH was in the most pleasant flying conditions only to arrive back at KTN to hot gusting winds.

This newsletter includes details of the AGM Programme which offers some new things as well as our traditional ground and flying activities. Also, this is the first time we have held an event at Bathurst.

As with our entire calendar of events, Bathurst details are first posted on the Airtourer Association web site well before any other medium. This is because the site is readily amended or updated thanks to John Day. The Events Committee, of which John is a member, have been able to meet and have the latest event information on the site that same night. Please develop the habit of checking the web site for the latest event information.

This year our winter gathering will be in Kyneton. The general plan is to meet for lunch at one of the many eating houses in town after which we can take in historic Piper St for afternoon tea. Anyone flying in can be collected and returned from the airfield which is a short distance from the town. We will make the decision on which eating house closer to the time.

Finally I notice that the HMS Pinafore, sorry CASA, has a new Captain. Seems the Government think that a prime qualification to being the so called Director of Air Safety is to have either been in the RAAF or flown for Cathay Pacific, or as in the last appointment both. On that basis we should be very nice to the two Johns, you never know!

On that note, safe and enjoyable flying.

I look forward to seeing you all at Bathurst in March.

Mike

Bicentennial Bathurst 2015 Airtourer Association Convention and 37th Annual General Meeting Bathurst NSW 20-23 March 2015

Helping to celebrate the City of Bathurst Bicentenary

Airport Facilities:

- Bathurst Aero Club will be our airport hosts for the weekend. The club rooms are open on Friday for members use. Tea/Coffee and soft drinks are available; please make payment by the honesty system.
- Generous space for parking is available in the area in front of the Aero Club.
- Bathurst is a security controlled airport. Entry to airside will be via the Aero Club.
- Alternately, a gate between the Club and terminal building provides on/off airside access-remember the CTAF and read instructions on the gate. If you have one please wear your ASIC.

Fuel Pump:

- Facilities are operated by the Aero Refulers and will accept their card or by credit card.

Registration Desk:

- Gerry Pels is the registrar please ensure you complete registration with Gerry.

Friday 20th March

Bus To Accommodation:

- First 1500
- Second 1600
- Last 1730 if required

Accommodation:

- Ben Chifley Motel, 272 Stewart St
- Governor Macquarie Motor Inn, 19 Charlotte St
- Panorama Motel, 51 Durham St

Bathurst Heritage Trail

- A walking tour led by Mike Fisher. Explore some of Bathurst's rich architectural heritage, commencing at the Ben Chifley Motel at 1630.

Shuttle Bus To Dinner:

- First 1830
- Second 1900

1900 Welcome Dinner:

- Church Bar and Woodfired Pizza, 1 Ribbon Gang Lane.
- Place your own orders for meals and drinks from the bar.
- We will be seated in the court yard.

Return Bus To Accommodation:

- First 2130
- Second 2230

Saturday 21th March**Start Of The Day:****0930-1100 Morning Coffee/Breakfast at the Crago Mill, 2A Piper St.**

- Cafe @ Crago Mill offers light breakfast, bacon and egg damper, croissants, muffins, pastries, toasted sandwiches and of course great coffee, tea and hot chocolate.
- Crago Mill is a Bathurst icon that started life over 100 years ago as a technology leading flour mill. Today it houses an assortment of businesses offering wine, antiques and gifts. Take some time to wander through these attractions.

Shuttle Bus From Accommodation To Mill:

- Bus will ferry everyone to the Mill from motels and then to the airport.
- First 0915
- Second 0930

Shuttle Bus From Mill To Airport:

- First 1100 - Pilots first please
- Second 1130

Return To Rylstone For Lunch And Flying:

- A pre-flight briefing will be presented at the Aero Club by The Airtourer Association for ALL participating pilots and will be a requirement for participation in this event.
- Plan for departure after 1200 for the short flight to Rylstone.
- Lunch will be catered by the Rylstone Volunteer Rescue Association and served

- around 1300 after which there is ample time for flying.
- Return to BTH at your leisure consistent with bus timetable.

Committee Meetings:

- Both are to be held at Rylston. Airtourer Co-operative Directors meeting 1400 and Airtourer Association Committee meeting 1430

Shuttle Bus From Airport To Accommodation:

- First 1600
- Second 1700

Shuttle Bus From Accommodation To AGM Dinner:

- First 1830
- Second 1845

1900 Convention Formal Dinner:

- Bathurst City Community Club, 29 William St, walking distance from Both Governor Macquarie and Panorama Motels.
- A sumptuous meal commencing with a choice of entrees followed by a two course buffet. Drinks pay as you go from the bar across the hall way.
- After dinner Guest speaker: David Crotty, Curator Qantas Heritage Collection, Qantas Airways Limited
- As well as spending some time in the right hand seat of an Airtourer David is a heritage professional who has worked as specialist curator with the Museum of Victoria, the Australian War Memorial and RAAF Museum. He is a recipient of a Churchill Fellowship. Now managing the QANTAS Heritage Collection David will give us an informed overview of how an Australian icon and major corporate views its own history.
- After 2200 members remaining are invited to move to the bar for the remainder of the evening.

Shuttle Bus To Accommodation:

- First 2215
- Second 2300

Sunday 22th March**Bus From Accommodation To Airfield:**

- First 0915
- Second 0945

Annual General Meetings:

- Both held at the Aero Club which will facilitate early departures. Tea/Coffee and soft drinks are available; please make payment by the honesty system.

NOTE: The bus will not be returning to the airfield

- 0930 Airtourer Co-operative Annual General Meeting
- 1000 Airtourer Association Annual General Meeting

The All Inclusive Womens Weekly Grand Tour:

- 1030 or at conclusion of the AGMs bus transport will leave the airfield and then go on tour for the rest of the day. Do not plan on there being time for the bus to return to the airfield after the tour.
- National Motor Racing Museum at Mount Panorama (tour will last about 1 hour plus 20 minute movie of Mount Panorama).
- Mayfields Gardens for the afternoon with lunch after 1330 (Mayfield Gardens is about 45 minutes drive by bus)

Bus From Accommodation To Dinner 1900**1930 Dinner:**

- Hotel Dudley corner Lambert and Stewart St which is easy walking distance from the Ben Chifley Motel.
- The Hotel Dudley is a nice, family friendly country pub that is popular with local families and visitors alike. Tables have been reserved for dinner at Stumpy's Bistro.
- Place your own orders for meals and drinks from the bar.

Return Bus To Accommodation By Negotiation With The Driver**Monday 23th March**

Shuttle bus to airfield starts at 0830 and as required.

Your Event Organising Committee

- John Day 0412 399329
- Niel Jensen 0447 758489 Transport Captain
- Mike Fisher 0429 869134
- Gerry Pels 0418 335965 Registrar
- Andrew Clement 0438 262315

The Airtourer Wing

An aircraft wing, more than any other major component, defines a flying vehicle as an aeroplane. It must be light weight, but strong enough to support the weight of the whole aeroplane, or in the case of an aircraft like an Airtourer, multiples of that weight during aerobatics.

The basic structure of a wing consists of a spar running spanwise and supporting the weight of the aircraft. Ribs provide the aerofoil shape and the skin give strength and generates the aerodynamic forces. In engineering terms the Airtourer wing is described as a twin cantilever spar torsion cell structure. Cantilever means the spar is continuous from tip to tip through the fuselage and torsion cell gives strength to the structure which is otherwise made up

of light flimsy materials.

The forward spar is made up of two booms of extruded aluminium T section. These form the upper and lower caps of the spar and are joined by a web of 0.028 inch alloy riveted to the forward vertical face of the T piece. Vertical stiffeners are riveted to both the booms and the web in between the ribs as shown in Fig. 1 making up the torsion cell.

Each boom is divided into three pieces with splice joints between ribs 5 and 6 on each side as shown in Fig. 2. Detail of the splice is shown in Fig. 3.

There is also a web splice between ribs 7 & 8 as shown in Fig. 2.

The boom cross-section on the

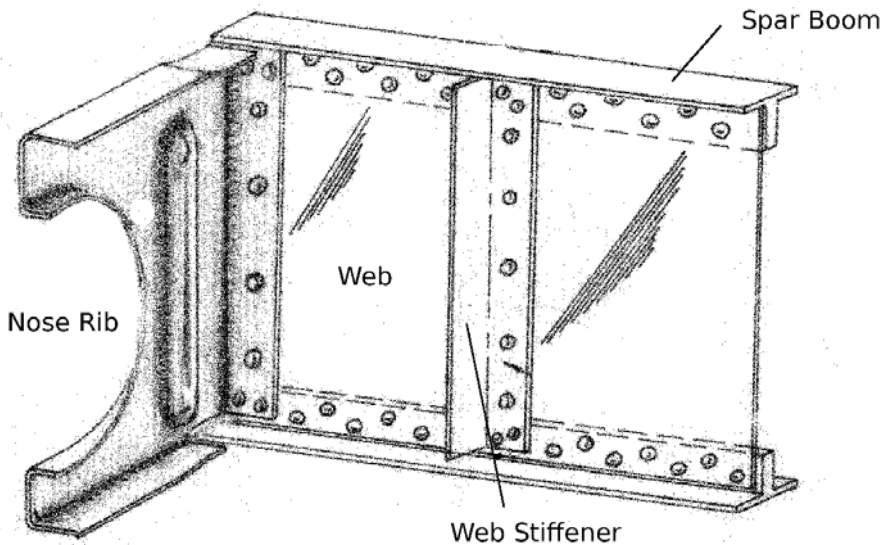

Figure 1: Section of main spar showing upper and lower T booms, spar web with stiffener and part of a nose rib riveted to the web.

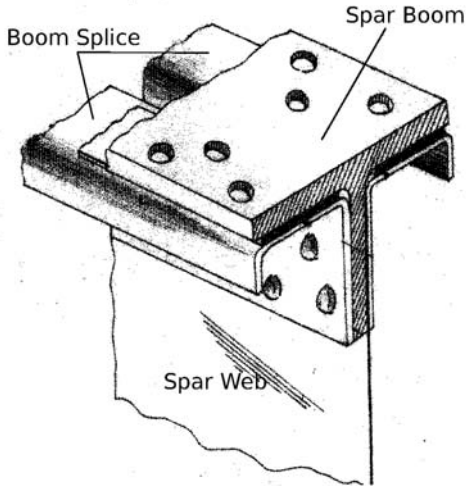

Figure 3: Detail of the boom splice.

centerpiece is constant but the sections outboard of rib 6 taper towards the tip. Each centre boom is bent at the wing root to provide a dihedral angle of 6 degrees.

The rear spar is similar to the main spar being in three sections although the booms are a channel cross-section. Again the outer pieces are tapered with the centre being of a constant cross-section. The inner section is also reinforced with two angle pieces giving heavier upper and lower booms between ribs 4 port and

starboard.

Washout is obtained by twisting the spars in a jig prior to installing the ribs and skin. Once the skins are attached the washout remains when the wing is removed from the jig. Each side of the wing has 14 ribs, each in two parts, a main and nose section, as shown in Fig. 4.

The main section of the rib is riveted to both the main and rear spar webs, (Fig. 1). Both main and nose sections are attached to the main spar booms by gussets which pick up on the rib flanges and are joggled under the horizontal leg of the T boom. (Fig. 4).

The leading edges include a span-wise stringer fitted to the under surface as shown in Fig. 2 to provide stiffening.

Span-wise stringers provide additional support for the walkway in the first three bays from the wing root. Additional shear webs are incorporated between ribs 2 and 3 forming the main undercarriage attachment structure, (Fig. 5). Rib 3 differs from the others being made of 2 pressings separated by the outboard undercarriage attachment blocks. (Fig. 5). Each block is aluminium with helicoil inserts.

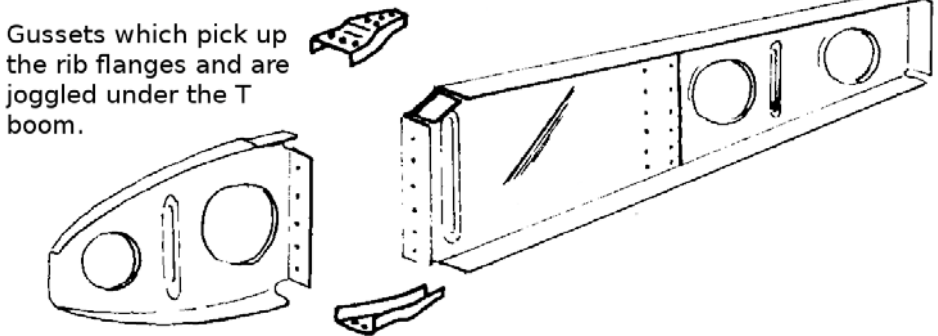

Figure 4: Typical rib nose and main section with gussets

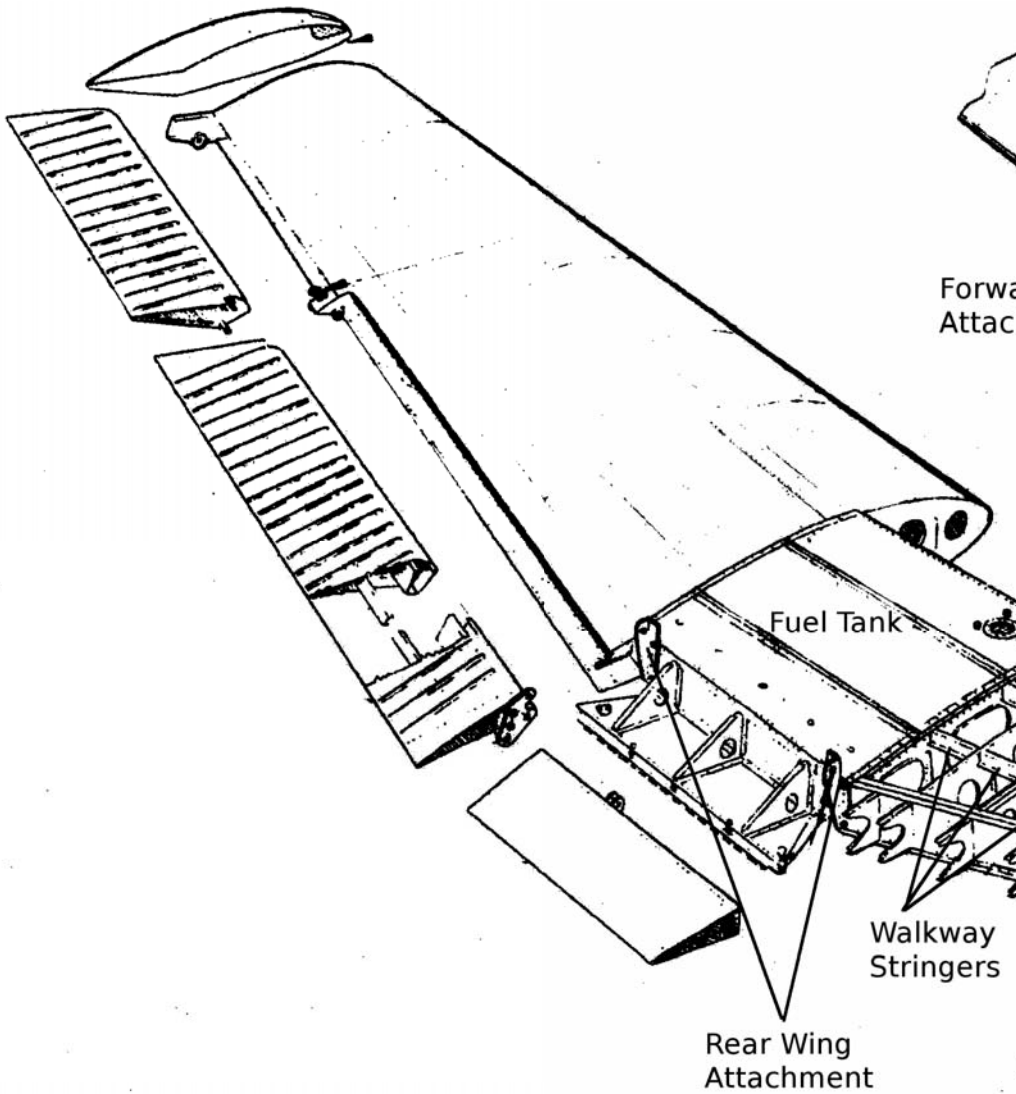
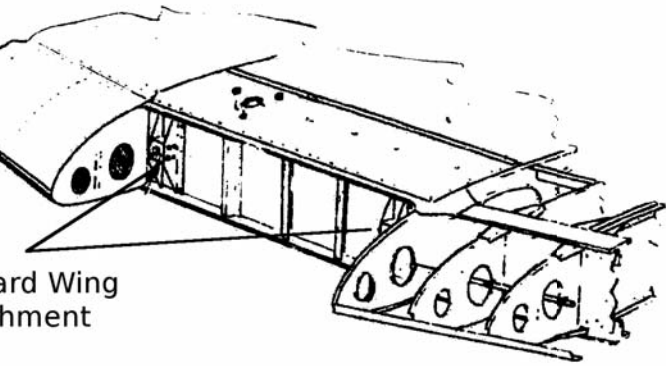
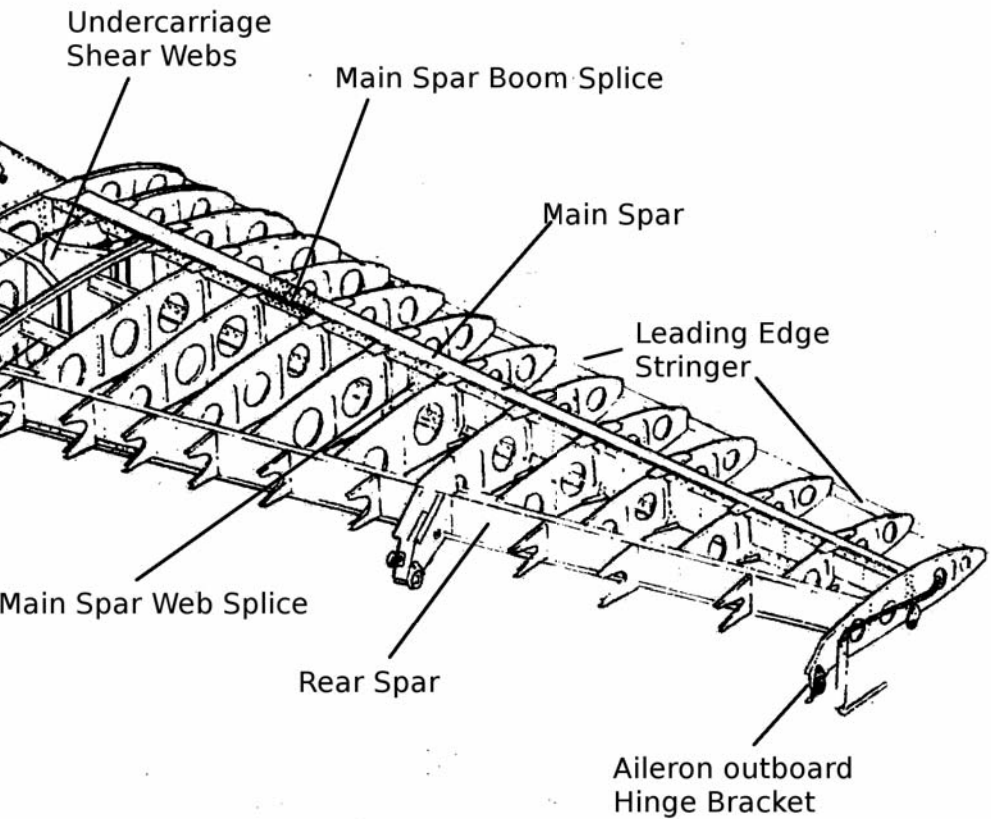

Figure 2: General arrangement of wing.



ard Wing
hment



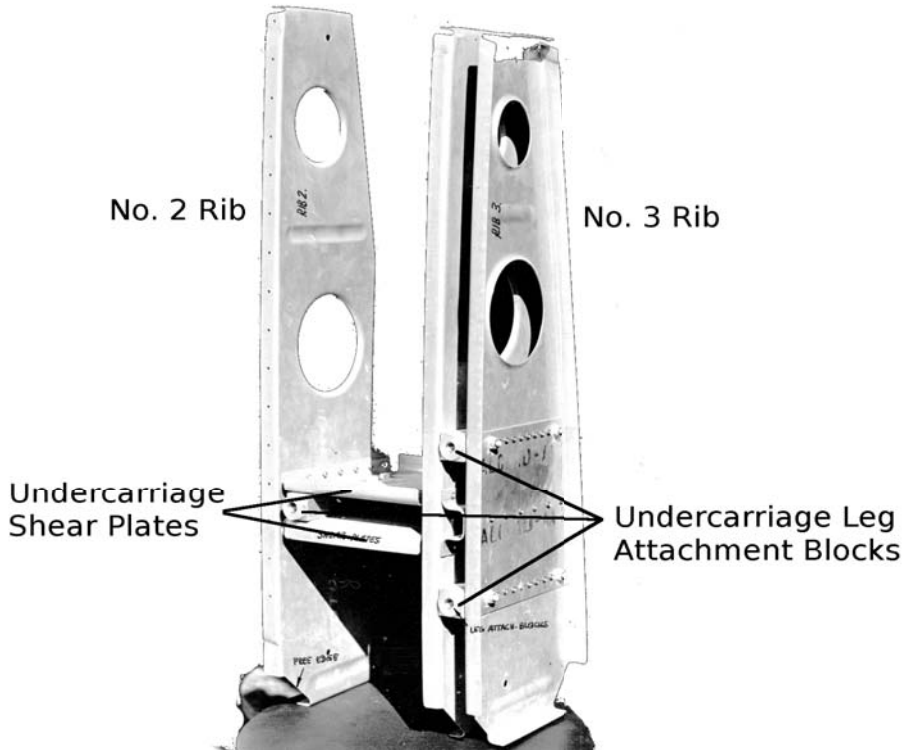

Figure 5: Rib 3 showing the two pressings.

The outermost rib is a single piece and includes the fibreglass wing tip attachment structure. The aft end extends past the rear spar and carries the outboard aileron hinge bearing. (Fig. 2)

The wing centre section holds the fuel tank. It is enclosed with an under-pan of aluminium alloy / polyurethane foam sandwich panel riveted to both spars and the first port and starboard main rib sections. The over-pan is a single alloy sheet broken up into panels by means of span-wise angles. The under-pan trailing edge extends aft of the rear spar and carries the attachment for the inboard flap bearing and the centre flap. The centre flap

is attached by a piano hinge.

The wing skin is light gauge aluminium alloy except for the walkways which are heavier.

There are four wing attachment points, two forward and two aft. The forward attachments consists of machined alloy blocks attached to the forward face of the centre section of the main spar. (Fig. 2) Two fore/aft pins attach these blocks to the forward wing attachment frame as described in Newsletter 131's article "Airtourer Fuselage". The aft attachment is achieved through two lug fittings on the rear spar, bolted to the fuselage with two span-wise bolts. These fittings are profiled from the same T section extrusion as used

for the main spar booms. (Fig 2)

Aerodynamically the wing uses conventional NACA sections with 3 degrees of washout. The shape varies from a NACA 2312 at the root to NACA 4412 at the tip. In both cases the aerofoil profile has been straightened aft of 70% chord to provide flat sided controls with no washout on their surfaces.

The combination of aerofoil sections and washout gives a mid-span stall which prevents either a sudden wing or nose drop.

Much detail of this article is hidden beneath the wing skins however, next time you are completing your preflight inspection pause at the wing tip and visualize the structure and shape along the span of the wing. This may help you appreciate the detail Henry put into the design that resulted in such a strong little aeroplane that is such a pleasure to fly.

What's a NACA 2312?

The wing article makes mention of NACA aerofoils, but what do those numbers mean?

Firstly, NACA was the National Advisory Committee for Aeronautics, a US Government research organisation formed in 1915. In 1958, in response to the developing space race it became NASA. It was tasked with conducting wide ranging aeronautical research and being a US Government organisation all its reports are available for free and make interesting reading. Just do an internet search for "NACA Reports".

NACA developed a system to describe aerofoil shapes using initially four digits. More complex shapes led to increasing numbers with the eight digit series describing supercritical aerofoils used on all modern airliners.

The four digit aerofoils used on the Airtourer define the shape in the following manner:

1. The first digit describes the maximum camber as a percentage of the chord.
2. The second defines the distance the maximum camber is from the leading edge in tens of percent of chord.
3. The last two digits describe the maximum thickness as a percent of the chord.

Therefore the NACA2312 has a maximum 2% camber located 30% from the leading edge and maximum thickness of 12%. The four digit aerofoils have the maximum thickness 30% from the leading edge by default.

If you look along the span of the Airtourer wing from the tip, can you see the difference in shape from the NACA2312 to NACA4412?

Airtourer Co-operative Ltd

Notice of Annual General Meeting

The Annual General Meeting of the Airtourer Co-operative will be held at the Bathurst Aero Club, Bathurst Airport, NSW, at 0930 on Sunday 22nd March 2015.

Agenda:

- Presentation of Minutes of the previous Annual General Meeting. (Published in the May 2014 Airtourer Association Newsletter. Available for download from website.)
- Business Arising from the Minutes.
- Chairman's Report
- Presentation of Accounts. (Available for viewing on the website.)
- Determination of Annual Subscription
- Election for retiring Board Members
- Other Business

Note: Only active members may vote at an AGM.

Proxy forms are available from the Airtourer Association website under *Airtourer Cooperative > Administration*

Airtourer Association Inc,

Notice of Annual General Meeting

The Annual General Meeting of the Airtourer Association will be held at the Bathurst Aero Club, Bathurst Airport, NSW, at 1000 on Sunday 22nd March 2015.

Agenda:

- Presentation of Minutes of the previous Annual General Meeting. (Published in the May 2014 Newsletter, available for download from the Association website.)
- Business Arising from the Minutes.
- Presentation of Reports. (Financial statements are available from the website for current members and included on pages 18 & 19 of this newsletter.)
- Election of Office Bearers
- Other Business

Proxies may be registered in accordance with the Rules of the Association. These Rules and the proxy form are available from the Association website under *Airtourer Association > Administration*.

Nomination for election as Director of the Airtourer Co-operative

The Airtourer Co-operative rules require that at the AGM two Directors stand down but are eligible for re-election without nomination. Additionally, other members may nominate for election if they are either active members in accordance with Rule 18, or are a person having special knowledge of the requirements to maintain the airworthiness of Airtourer series aircraft.

Any person wishing to nominate for election as a Director should do so in writing to the Chairman prior to the AGM.

Heard At the Hangar Door

The Association was saddened to learn of the passing of **Frank Fankhauser** late last year at the age of 94. Frank had been a member of the Association for many years and with son Stephen restored UQX under the watchful eye of Maurice Rolf.

Kerry Pearce has sold Airtourer 150 RSJ and “upgraded” to CT4 A19-74, VH-APV.

Congratulations to AVM **Mel Hupfeld** on being made an Officer of the Order Of Australia in the Military Division. The citation read:

“For distinguished service to the Australian Defence Force in senior command and staff appointments. Air Vice -Marshal Hupfeld is the epitome of professionalism who has distinguished himself through exceptional leadership that has shaped the operational tasking of air assets; enhanced Air Force’s reputation with the United States military; and expertly delivered Air Force’s operational capability in an environment of constrained resources. His enduring achievements have brought great credit upon himself and the Royal Australian Air Force, and are in the finest traditions of the Australian Defence Force”.

Mel is one of the owners of Airtourer 150 MTP and son of Peter and Bernardine who fly Airtourer 100 WHO.

Airtourer Co-operative Financial Statements.

The financial statements for the Airtourer Co-operative were still with the accountant at time of publishing. They will be available for review by Co-op members on the website in the near future.

Disclaimer

All flying activities are carried out at the discretion of the pilot in command or aircraft owner. The Airtourer Association is not responsible for flying operations. Safety of flight is the individual responsibility of the pilot in command or aircraft owner at all times. Familiarity and knowledge of standard operating procedures, published aerodrome regulations and operating procedures and government imposed rules, regulations or specific procedures are the responsibility of the pilot in command.

A Note on Bus Transport at Bathurst

Bus transport is provided as a courtesy to all members and is not intended to be a private taxi service. Please observe the published ground transport schedule. If your needs are outside this please make other arrangements.

Bathurst Accommodation

NOTE: Cut Off Date for these rates is 27 Feb. There are other events over that weekend so rooms are filling up.

Panorama Motel Bathurst

51 Durham Bathurst NSW 2795

Ph: 02 6331 2666 email: reservations@panoramabathurst.com.au

Double Rooms start \$95 per night

Ben Chifley Motor Inn

272 Stewart street Bathurst NSW 2795

Ph: 02 6331 5055 email: stay@benchifleymotorinn.com.au

Double rooms start \$115 per night

Governor Macquarie Motor Inn

19 Charlotte Street Bathurst NSW 2795

Ph: 02 6331 2211 email: contact@governormacquarie.com.au

Double rooms start \$114 per night

Airtourer Association Convention and AGM 2015
Bathurst NSW, 20th to 22nd March 2015
Registration Form

If you are planning to attend this event it's recommended you secure your accommodation ASAP. Advise that you are part of the Airtourer group. Accommodation details are published on the previous page.

Captain and Passenger name.....VH-.....
 Accommodation details:.....
 Arrival day..... Departure day.....

If attending all functions the total cost will be \$140.00 per person, which includes all Transport, Saturday lunch & dinner/Sunday lunch/NMRM/Mayfields entrance.

For catering and venue requirements, complete the following details.

Will you be attending Church Bar and Woodfired Pizza Friday night?	Yes/No
Will you be having breakfast at 'Café @ Crago Mill' Saturday morning?	Yes/No
Will you be attending lunch on Saturday Rylstone Aero Club?	Yes/No
Will you be attending AGM dinner on Saturday?	Yes/No
Will you be attending the National Motor Racing Museum Sunday?	Yes/No
Will you be attending Mayfields Gardens tour and Sunday lunch?	Yes/No

\$60 deposit per person. Number of persons.....X \$60 = \$

Indicate if paying by Internet. Yes/No

There are two options for paying your deposit:-

1. Do everything online. Pay the deposit and register via the website online registration form.
2. Send this form and a cheque to:
 Treasurer, Airtourer Association
 84 Santa Rosa Boulevard
 Doncaster East, 3109

Electronic Funds Transfer.

Bank account details: Airtourer Association, Westpac **BSB No. 033 028, Account No. 460085.** please quote your name.

Post your completed Registration form to above address or via email:

treasurer@airtourer.asn.au

Registration form and deposit to be forwarded by 6th March. After this date the return of your deposit cannot be guaranteed.

**Airtourer Association
Annual General Meeting
Bathurst NSW 22nd March 2015
Statement of Receipts and Expenditure
1st January 14 to 31st December 2014**

	Year ending 31 Dec. 2014.	Year ending 31 Dec. 2013
REVENUE	\$	\$
Membership Fees	8,117.00	5,600.00
AGM	6,420.00	8,278.00
Presidents 'Fly in'	3,930.00	1,440.00
Member RFDS contributions	116.00	544.00
Interest [term deposit]	1,260.00	1,462.00
Total Revenue	19,843.00	17,324.00
 EXPENSES		
Bank Fees	12.00	118.00
AGM	5,591.00	9,192.00
Presidents 'Fly In'	3,268.00	618.00
Newsletter/stationery/postage	1,859.00	1,470.00
Public Liability insurance/Directors insurance	1,700.00	2,407.00
AOPA subs	160.00	140.00
Jumba internet		
Badges/pins		0.00
Stationery/mail out		340.00
RFDS donation		95.00
Registry of Associations	52.00	51.00
Total Expenses	12,590.00	14,431.00
 SURPLUS(DEFICIT)	 7,253.00	 2,893.00

Airtourer Association Balance Sheet

	31-Dec-14	31-Dec-13
	\$	\$
MEMBERS EQUITY		
Surplus/Deficit this year	7,253.00	2,893.00
Retained Surplus(Deficit)	37,806.00	34,913.00
TOTAL MEMBERS EQUITY	45,059.00	37,806.00
Represented by:		
CURRENT ASSETS		
Bank - current account	6,464.00	5,344.00
Cash on deposit	38,595.00	32,462.00
TOTAL CURRENT ASSETS	45,059.00	37,806.00
TOTAL ASSETS	45,059.00	37,806.00
TOTAL LIABILITIES		
NET ASSETS	45,059.00	37,806.00

Gerry Pels - Treasurer

John Treble - Reviewer

Calendar of Events

Convention and AGMs 2015

The 2015 Airtourer Association Convention and 37th Annual General Meeting will be held over the weekend of 20th to 23rd of March in Bathurst.

See this Newsletter for details.

Mid Year Lunch 2015

The 2015 Mid Year Lunch will be held on Sunday the 14th of June 2015 at Kyneton.

Airtourer Association Nomination for Election to the Committee

I nominate _____

for the position of: *(mark appropriate position)*

President

Vice President

Secretary

Treasurer

Ordinary Members (three positions)

Nominated by (Signature) _____

(Name) _____

Seconded by (Signature) _____

(Name) _____

I agree to being nominated for the above mentioned position.

Signature of candidate:

Date:

Note: this form will be available for download from the Association website under *Airtourer Association > Administration*